

Wheel-Horse

Reg. U. S. Pat. Off.

RMR-32 ROTARY MOWER

PARTS LIST AND INSTRUCTIONS

TO ASSEMBLE: The Rotary Lawn Mower is shipped complete in one carton. **STEP 1.** Remove from carton. **2.** Remove the front two bolts in the left-mounting angle on the mower deck. **3.** Install the hangers inside the two angles and rebolt the mounting angle. **4.** Attach the lift rod to the rear deck angle with the hair cotter pin.

TO ATTACH TO TRACTOR: **5.** With the mower hangers down and toward the front, and the lift rod under the deck, slide the mower under the center of the tractor from the tractor's right side. Be sure front of mower is toward front of tractor. **6.** Swing the hangers up inside the tractor frame angles and bolt in the 2nd and 4th holes (from front) in the tractor frame. Use the 6 1/2" machine bolts provided. **7.** Place the lift bar in the rear tractor hitch. **8.** Depress button on top of lift lever and move lever forward to front notch in multi-notched sector. Release button on lift lever and allow ratchet to lock in notch. **9.** Place lift rod in the lift bar. This is held in place with a 1/8 x 1 cotter pin. **10.** Fasten the clutch link to the mower clutch pedal with a 1/8 x 1 cotter pin. The clutch pedal operates over the right tractor foot rest.

TO ATTACH 30" BELT: **11.** Move the clutch pedal up and back as far as possible. **12.** Place the belt over the power take-off pulley on the tractor and the outside groove of the mower pulley. **13.** Bolt the belt guard to the engine and the vertical tractor-hood support.

MOWER ADJUSTMENTS TO MAKE: The cutting height is adjusted with the lift lever. You have a selection of 10 different cutting heights. **14.** To set the desired cutting height, move the lift lever until the desired cutting height is reached. Release the lift lever lock button. Your mower can now float up from that height but will not cut any lower.

BELT ADJUSTMENTS TO MAKE: Each mower belt has a different adjustment. The stud for the double pulley is located in a slot. **15.** To tighten the 24" belt, loosen the bolt holding the stud,

tighten the belt and retighten the stud. **16.** To tighten the 30" belt, loosen the nuts on the clutch link. With the mower clutch pedal depressed, turn the rear nut clockwise until belt becomes tight. **17.** Lock the other nut against the bracket. **CAUTION:** Making belts too tight will reduce the life of the belt and bearings.

TO LUBRICATE MOWER: There are four high pressure grease fittings on the mower. These are shown in the drawing. **18.** Lubricate these four fittings each time before using mower and periodically during extended use. **CAUTION:** Do not over grease the double pulley, allowing grease to get on belts.

TO OPERATE MOWER: **19.** To operate mower, depress the clutch pedal. **20.** Pull lift lever back to put mower at its highest or travel height level. **21.** Start engine of tractor. **22.** To start mower running, slowly depress clutch pedal. **23.** Set the mower at the desired cutting height. You are now mowing. The ground speed of the tractor will depend on the condition of the grass to be mowed.

TO CHECK MOWER: (DO NOT MAKE ADJUSTMENTS WHILE TRACTOR ENGINE IS RUNNING). The throw out finger in the belt guard should be checked so it does not rub the belt while the clutch pedal is engaged. This should be checked with the mower at both its highest and lowest levels. If the mower does not cut the grass evenly, the tire pressure should be checked. Strict care should be used to keep hands and feet away from front and rear openings and from underneath the housing when the mower is running.

PARTS LIST for RMR-32

Ref. No.	Part No.	Description	No. Req.
1	3192	Deck	1
2	3195	Twin Housing	1
3	3154	Spindle & Tip Carrier	2
4	3185	Hanger	2
5	3190	Pivot Arm	1
6	3187	Lift Bar	1
7	3191	Mounting Angle Ass'y R.H.	1
8	3162	Mounting Angle L.H.	1
9	3194	Belt Guard	1
10	3196	Clutch Link	1
11	3156	Clutch Pedal	1
12	3188	Lift Rod	1
13	3184	Stud—Double Groove Pulley	1
14	3157	Bracket—Clutch Link	1
15	3181	Heel Stop	2
16	3138	Bearing Block	2
17	3155	Cross Shaft	1
18	3130	Face Gear	2

(Continued)

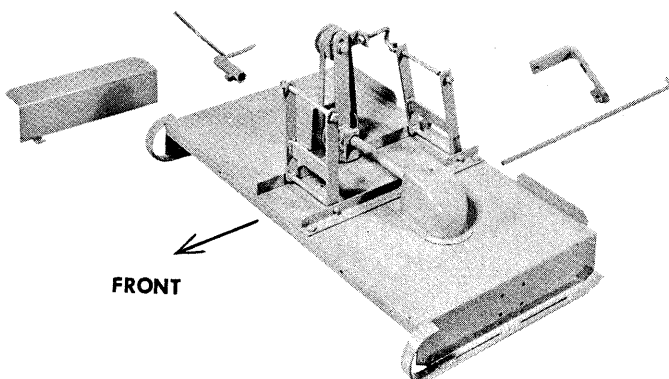

WHEEL-HORSE PRODUCTS

● SOUTH BEND, INDIANA

PARTS LIST for RMR-32 (continued)

Ref. No.	Part No.	Description	No. Req.
19	3131	Spur Gear	2
20	3141	Gear Cover	2
21	3133 R	Blade Tip	2
22	3133 L	Blade Tip	2
23	1613	Pulley V 3 1/2 O.D.	1
24	1561	Belt V 30 A	1
25	1554	Belt V 24 A	1
26	1515	Ball Bearing 3/4 x 1 5/8 x 1/2	6
27	1617	Pulley 2 Groove 2 1/2 O.D.	1
28	1524	Bronze Bearing 3/4 I.D. x 7/8 O.D. x 1 3/8	1
29	3182	Tube Guard Mount	1
30	1009	Cap Screw 1/4-20 x 1/2	9
31	1061	Cap Screw 3/8-16 x 3/4	6
32	1062	Cap Screw 3/8-16 x 1	5
33	1205	Cap Screw 5/16-24 x 3/16	8
34	1259	Cap Screw 5/16-24 x 3 3/4	1
35	1289	Machine Bolt 3/8-16 x 6 1/2	2

Ref. No.	Part No.	Description	No. Req.
36	1202	Machine Screw #8-32 x 1/4	8
37	1016	Hex Nut 3/8-16	8
38	1183	Hex Nut 5/16-24	8
39	1203	Hex Nut 5/8-18	2
40	1034	Hex Nut 1/4-20	5
41	1067	Shakeproof 1/4	9
42	1196	Shakeproof 3/16	9
43	1039	Lockwasher 3/8	11
44	1185	Lockwasher 5/8	2
45	1197	Washer 3/4 x 1 x 21 Ga	4
46	1194	Woodruff Key #5	4
47	1122	Woodruff Key #9	1
48	1002	Cotter Pin 1/8 x 1	2
49	1290	Hair Pin Cotter 1/8	1
50	1133	Roll Pin 3/16 x 1	2
51	1030	Grease Fitting 1/4-28	4
52	1128	Snap Ring 1	1
53	1041	Washer 3/8	1
54	1127	Snap Ring 3/4	1

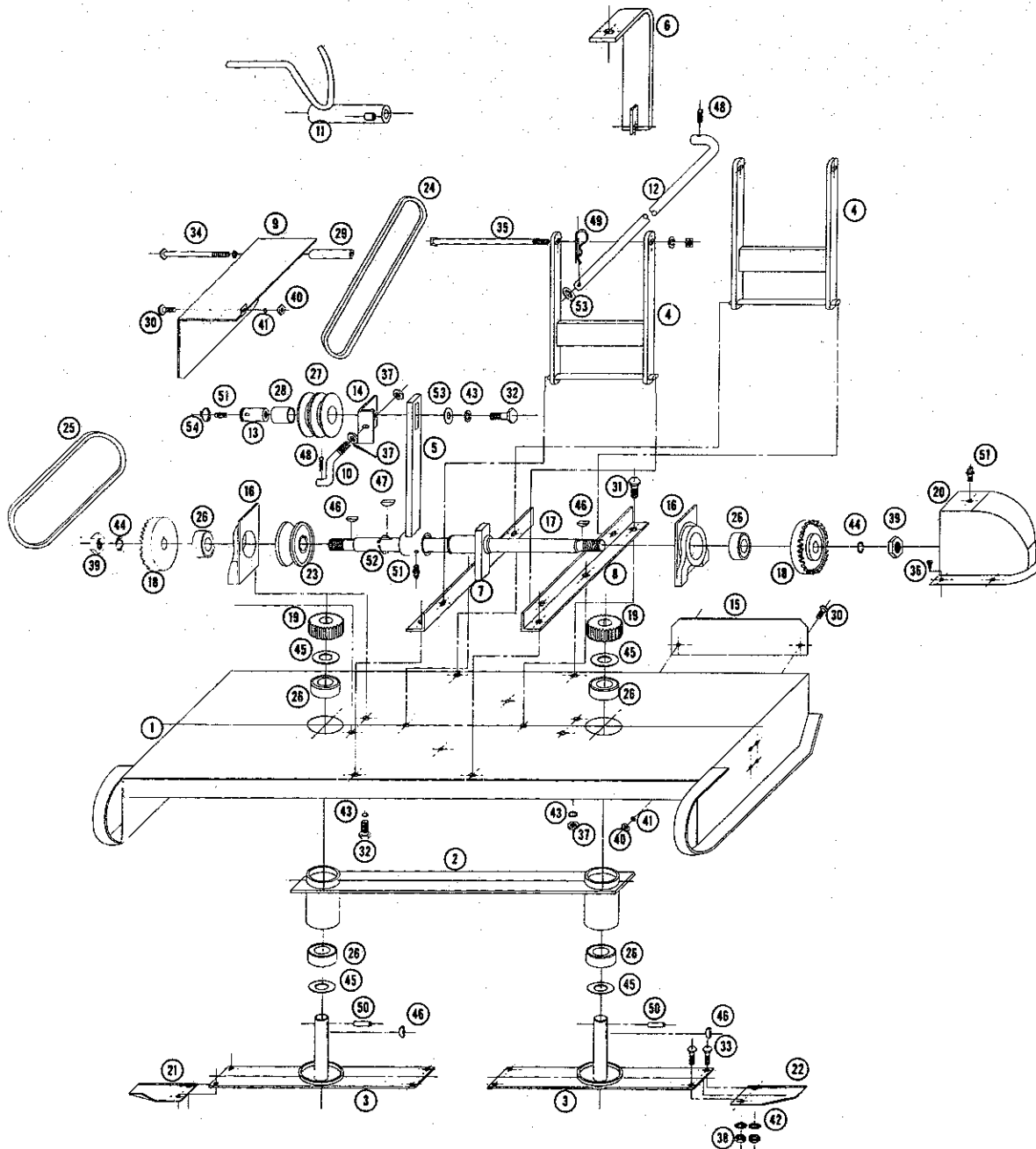

Wheel Horse Service Bulletins 1961 - 1990: **#306** Issued: May 1981

Replacement Blade Tips for RMR-32

[Previous](#) [Table of Contents](#) [Next](#)

TO ALL DEALERS:

1. Subject

1.1 Replacement blade tips for the above model mowers have been packaged in kit form for your convenience in ordering.* The kit contains all parts needed to service one mower:

QTY.	PART NO.	DESCRIPTION
2	3133	Blade Tip RH
2	3147	Blade Tip LH
8	108686	Special Bolt 5/16-24 x 5/8
8	108687	Special Nut 5/16-24
8	920008	Washer 5/16 SAE

2. Service Action

2.1 Order Service Assembly 6005 to service the blade tips on RMR-32 mowers, one kit per mower.

ROUTING	SERVICE MANAGER	SALES MANAGER	PARTS MANAGER	CHIEF MECHANIC	MECHANIC NO 1	MECHANIC NO 2	MECHANIC NO 3	MECHANIC NO 4	RETURN THIS TO
INITIAL HERE									

* Due to a stock imbalance, P/N 3147 Blade Tip will remain available until present stock is exhausted.